



**BEUMER**  
technology in motion



Conveying technology   Loading technology   Palletising technology   Packaging technology   Sortation and distribution technology

**BEUMER sortation and distribution technology**  
**To help you arrive swiftly and smoothly**  
**at your destination.**





**BEUMER. Always in motion for a smooth workflow.**

Most BEUMER sorters are equipped with a contactless energy and data supply system. That means less wear and less maintenance. They are particularly flexible due to their modular design. They are extremely quiet, creating a pleasant working atmosphere for your employees.

Dynamic induction and gentle discharge contribute to a smooth and reliable workflow.

**BEUMER sortation and distribution technology  
Profitability, speed and precision –  
system solutions that get the job done.**





**Our experience – your advantage.**

As an international leader in the manufacture of intralogistics products in the fields of conveying, loading, palletising, packaging, sortation and distribution technology, we know the routes your goods and products take and know what matters most.

Whether in the service sector or in industry – the demands on modern sortation and distribution systems are constantly increasing. Complex material distribution technology, flexibility in sorter tasks, the ability to adapt to local conditions and efficient order picking all play important roles. With sophisticated designs, BEUMER offers individualised system solutions with powerful software that impress with their profitability, speed and precision. Years of experience

designing user-specific systems and continuous research and development work reflect BEUMER’s expertise. In our testing hall, various applications are tested regularly and new solutions are developed, for example in the areas of ergonomics, noise generation or product handling.

**High performance at the right time, at the right place.**

The BEUMER product range comprises fully automatic conveying and distribution systems for all kinds of piece goods. In courier, expedited and parcel services, mail-order businesses, retail distribution or airports: the computer-controlled BEUMER sortation systems – which meet all modern standards of quality – stand for high levels of availability, low maintenance costs and a top perform-



ance of up to 40,000 units per hour. Specific customer demands, such as optical character recognition (OCR) “on-the-fly”, certified weighing on the induction unit or certified volume measurement on the sorter, are no problem.

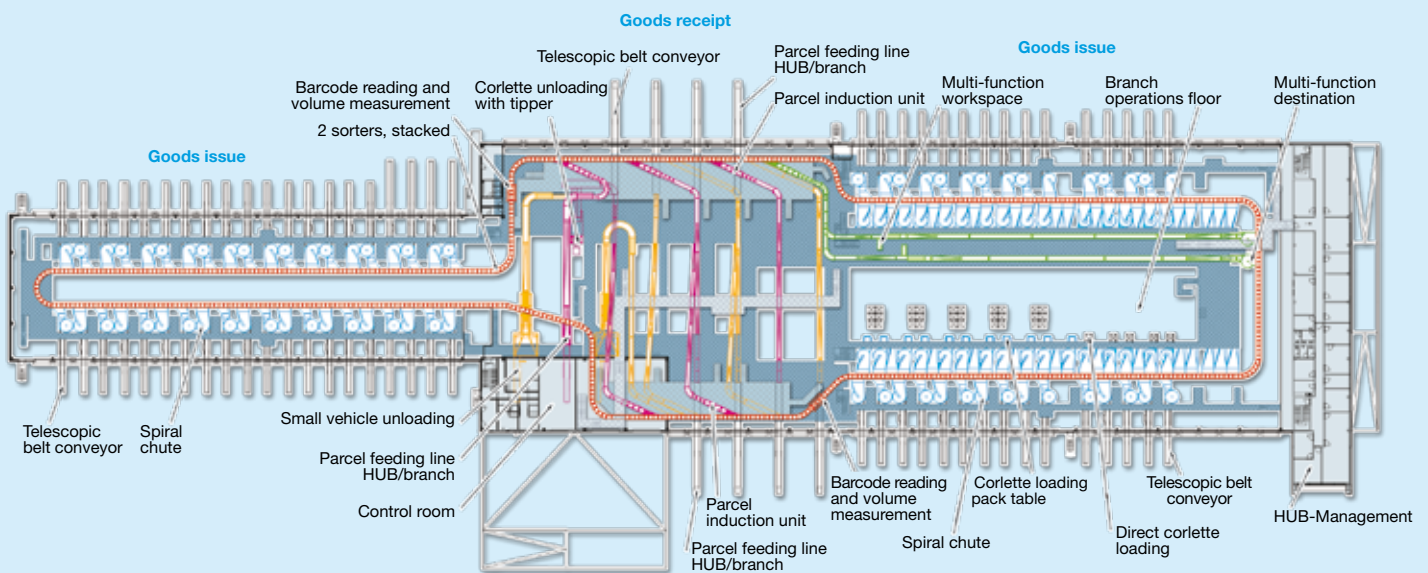

Technical layout of the NORD-HUB of Hermes Logistik Gruppe Deutschland



**The outstanding features of the BEUMER Tilt Tray Sorter are:**

- exceptional sorting quality
- gentle item handling
- robust design
- low-maintenance tilt element, electrical or mechanical
- guided, two-dimensional discharge
- low-maintenance, low-wear linear motor drive, alternatively the energy efficient OptiDrive design
- low-noise running characteristics
- modular design

**Courier, expedited and parcel services  
Individual, economical solutions  
for a dynamic market.**



1.



**We know the demands of the market.**

A high level of economic efficiency combined with highest sorting capacities for various item sizes – these are the requirements of modern courier, expedited and parcel services. Powerful, strategically positioned sortation and distribution centres (HUBs) equipped with sophisticated plant technology are required to be able to provide a seamless supply network.

BEUMER sortation and distribution systems provide you with a robust, powerful overall system you can rely on. At any time. The BEUMER sorters convince by providing creative solutions for individual applications while ensuring smooth handling of items.



**Smooth discharge – one of our specialities.**

The BEUMER Tilt Tray Sorter is the basic model of our modular system. The mechanical tilt elements enable a guided, two-dimensional discharge of the items to both sides. This makes the item slide off the tray without any catapult effect so that it leaves the tray at a clearly lower speed than with comparable systems. Large envelopes, parcels, packages and other sorting items are transported safely and discharged with maximum accuracy.

The tilt element of the BEUMER E-Tray Sorter is driven by an electric motor. The tilt elements are powered by contactless energy supply. Thus the tilting and running noise is reduced. The tilting movement is decoupled from the sorter speed so that the sorter speed is considerably increased.



**BEUMER – always close to our customers.**

BEUMER develops customised solutions – from stand-alone machines to centralised, software-controlled material handling systems. Continuous and competent customer support, as well as reliable worldwide service, including repair and maintenance, complete the performance. In urgent cases, customers can contact us via the BEUMER Hotline at any time.



2.



3.



4.



5.

1. BEUMER Sorter BS 25 ET with contactless energy supply
2. BEUMER Sorter BS 25 MT-2D
3. BEUMER Sorter BS 25 MT-3D
4. BEUMER Sorter BS 25 MT-DD
5. BEUMER Sorter BS 25 BT with contactless energy supply



**The outstanding features of the BEUMER Belt Tray Sorter are:**

- power supply on demand, due to the contactless energy supply system
- modular design
- standard PLC with worldwide service
- minimal maintenance requirements, easy access
- considerably lower maintenance costs compared to conventional energy supply systems

Mail order

**Our engineers have but one goal:  
customer satisfaction.**

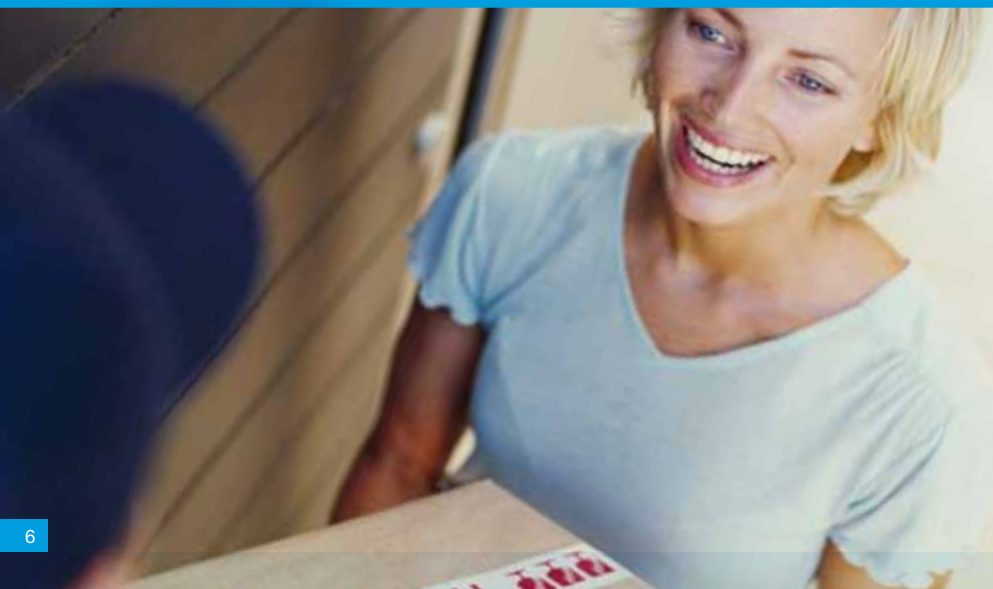



**We always have just the thing.**

Your customers expect around-the-clock delivery of goods in perfect condition. They expect a sorter that can transport and sort everything from camping equipment to shoes or clothing quickly, precisely and gently. One that is flexible enough to react to changing product lines and seasonal workloads.

BEUMER sortation and distribution technology always has the right solution. Depending on the requirements and characteristics of the items to be conveyed, you can select either the BEUMER Belt Tray Sorter or the BEUMER Tilt Tray Sorter. Make your choice; reliable logistics means satisfied customers.



**An accurate grip on returns.**

Goods that do not fit or are not liked are returned by the end consumer. Returns handling poses a problem for mail-order business that needs to be solved. BEUMER develops complete customised concepts, taking all technical and economical challenges into account, such as multiple uses for returns sorters. The ergonomic design of the destinations plays an important role. Your employees will have everything under control, including their fatigue.



**BEUMER sorter control and sortation systems.**

All machine-relevant functions are controlled by a programmable logic controller suited for industrial use. This real-time system, with worldwide maintenance service, executes control commands for all mechanical components of the BEUMER sorter and its peripherals (induction unit, scanner and destinations)



and processes the signals from all sensors and watchdog units. The BEUMER sorter control comprises remote input/output devices that are networked via a standardised PROFIBUS/AS-i bus system. The BEUMER Sortation System is a PC-based Windows server, which represents the upper control levels and communicates with the customer host.

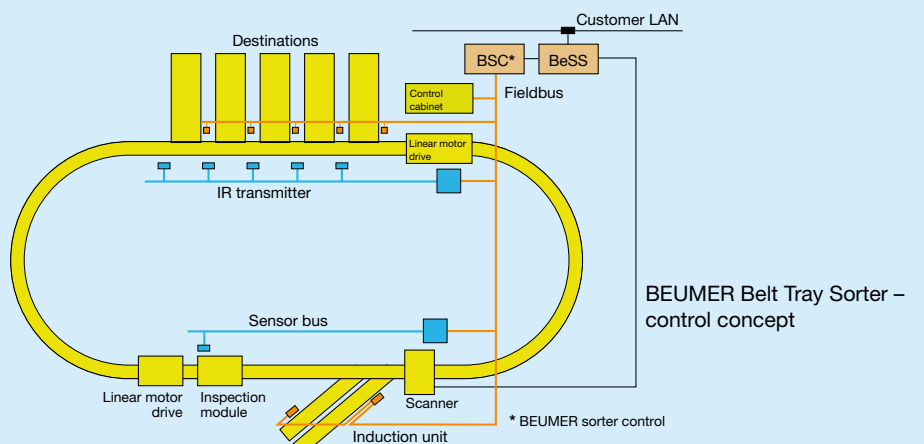

Exemplary technical layout of a control configuration for the Belt Tray Sorter



Retail distribution / Non-food items

**Gentle, smooth and safe – always on the right track.**





**Every product has its own format.**

Books, CDs and DVDs, magazines, newspaper bundles, clothing, shoes, drugstore goods or car parts – as diverse as the demands of retail distribution on a modern sortation and distribution system are, so diverse are the solutions BEUMER offers with its high-performance sortation systems. The focus is on – in addition to the profitability of the overall machine – quick, smooth, flawless order picking, depending on the size, weight, shape and surface characteristics of the individual piece goods.

Just how successful BEUMER is with its designs can be seen in the numerous references from the clothing industry,



drugstore chains, from the fields of spare parts logistics, print media and multi-media.

Various demands can be met, depending on the individual customer needs:

- high sorter capacity
- gentle handling of sorted goods
- induction and discharge tailored to the different items
- shipment tracking
- group sortation
- product labelling (value added service)
- printing shipping documents

**BEUMER makes everything go smoothly.**

The BEUMER Belt Tray Sorter with contactless energy supply and linear motor drive is a sortation system often used for retail distribution. From goods packaged in film with a high coefficient of friction (anti-slip surface) or shoe boxes to goods packaged in polybags – the BEUMER Belt Tray Sorter reliably and smoothly transports all items to the correct destination.

The functional basis of the sorter is a series of moving conveyor belts, which move at a 90° angle to the direction of sorter travel. After activating the corresponding belt tray, the product is fed onto the belt tray at a speed adjusted



to the speed of the sorter and the angle of induction. The discharge process is adapted to the product's characteristics.

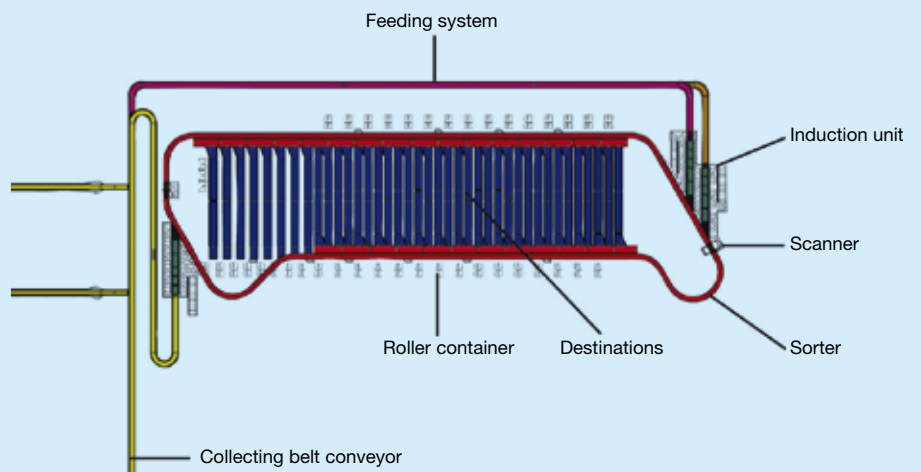

Technical layout of a BEUMER sortation system for the DIRK ROSSMAN GmbH logistics centre



Retail distribution / Food items

**The right solution for every task –  
completely your taste.**





### Always fresh on the table.

In the food industry, quick but gentle product sortation is imperative. Perishable or damageable items such as frozen foods, baked goods or dairy products require a high performance sortation system that meets the respective product requirements and the statutory regulations with regard to hygienic handling.

The BEUMER sorters are – in addition to a number of other outstanding features, such as minimal maintenance requirements and easy access – also designed for applications in temperatures ranging to  $-30^{\circ}\text{C}$ . All products arrive at the customer safe and fresh.



### Customised order picking.

One of the leading companies for meat products processes up to 1,400 orders with 80,000 order units selected from a product range with 800 items daily. A BEUMER high-performance sortation system BS 25 MT-3D takes care of the smooth processing.

The orders are processed in 24-hour cycles. The store-related, two-stage order picking is performed directly at the manufacturer. That means a high level of economic efficiency and profitability for the company.

Via a total of 6 induction units, the order units are distributed across 150 destinations at a sorter speed of 1.5 m/s and a sorter tray capacity of 10,000 per hour, where they are precisely and gently discharged. That is customised order picking.

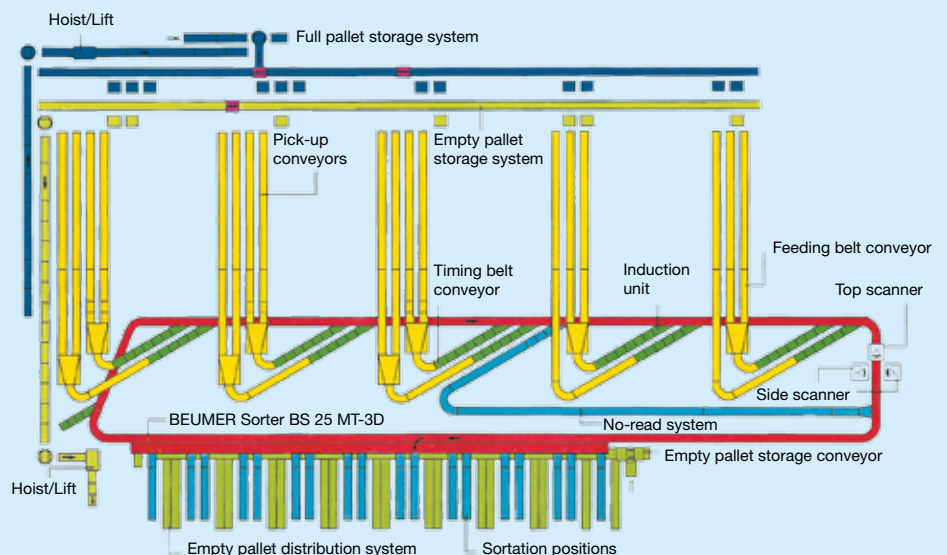

Technical layout of a food order picking system for Nestlé Germany



Airports

**Sortation and distribution technology  
for a safe arrival. Worldwide.**





**Baggage handling systems from BEUMER – powerful, gentle and safe.**

International and regional airports are registering steady growth in the volume of passenger traffic.

In order to continue to ensure safe and flexible baggage handling, a powerful BEUMER baggage transport and distribution system is necessary.

Be it a central sortation concept with Tilt Tray Sorters or a decentralised design with destination-programmed transport vehicles – the individually designed BEUMER solutions have proven themselves worldwide. System control, process computers and the corresponding peripherals supplement the scope of service and make distribution capacities of up to 10,000 suitcases per hour

possible. With the BEUMER baggage handling system, the increasing numbers of passengers can be handled with ease. For the passengers, this means short waiting times at check-in, gentle baggage handling and short transfer times.

**State-of-the-art technology – start to finish.**

BEUMER baggage handling systems prove themselves in daily operation. Precise and reliable. In Dubai, Sydney, Hamburg, Heathrow T5 and Beijing.

BEUMER Belt Tray Sorter or BEUMER Tilt Tray Sorter – the robust sortation systems distinguish themselves through their state-of-the-art technology, long service life and high level of availability. Interruptions caused by baggage can be reduced considerably using the BEUMER Sorter BS 55 ET-CD, with its closed surface. Systems of this type reduce possible downtime and increase the efficiency of the entire baggage system.

The BEUMER autover® BA 55 works with rail-mounted, self-propelled transport vehicles, the BEUMER autoca® BC 55.

Equipped with their own onboard path finding computer, speed controls and active switch controls, the transport vehicles have a contactless energy and data supply.

The BEUMER autover® BA 55 conveys, stores and sorts with a high level of reliability at speeds up to 10 m/s. Thanks to computer-supported rail management and a simple rail system, expansions are possible any time at a low cost.





## Tailor-made solutions from the intralogistics experts. BEUMER worldwide.



**We are always there when you need us!**

### **Worldwide service.**

Our service managers' regular inspections ensure:

- Sustained operational capability of your equipment
- Reduction of downtimes
- Sharing of best practices
- Qualification of the maintenance team
- Continuous product optimisation
- Spare parts optimisation

### **Trouble-shooting/BEUMER Hotline.**

- Qualified worldwide support on short notice
- Online trouble-shooting
- Worldwide availability of service engineers
- On-demand deployment option
- Fast, responsive service on the ground in real time

### **Technical consulting.**

We can advise and train your staff, either in our own training centre or at your designated facility. This ensures:

- Optimal equipment and system operation
- Qualified evaluation of equipment condition
- Long-term optimisation strategies

### **Maintenance and repairs.**

- Personnel specifically qualified for your equipment
- Foundation for superior operational reliability
- Qualification of your personnel in all facets of maintenance



**We know the way. Worldwide.**

As one of the international leaders in the manufacture of intralogistics for conveying, loading, palletising, packaging, sortation and distribution technologies, we know the routes your products take and their unique handling characteristics. This knowledge is integrated into the development and manufacturing processes for all our equipment and systems.

We maintain and ensure proximity to our customers in every part of the world through a global sales and service network. The BEUMER story is far reaching. A team of 2,000 professionals worldwide. Annual turnover of 375 million EUR. Wholly owned subsidiaries and holding companies on each continent and representatives in over 70 countries. Each of these elements contributes to a solid foundation for our export-orientated activities.

And our presence on the ground ensures individual adaptation to local requirements. Location-relevant solutions are the result of our constant close cooperation with our customers.

**Our corporate philosophy.**

Family spirit is a fundamental factor in the success of BEUMER as a globally operating concern. Shareholders, executive management and staff are essential members of a community in which constructive cooperation is the hallmark of our corporate philosophy. The owners' commitment to considerable reinvestment in the company is a prerequisite for securing the future, and is the basis for the success-oriented partnerships between our company and our customers.





**BEUMER**  
technology in motion

**BEUMER Group GmbH & Co. KG**  
PO Box 1254 · 59267 Beckum · Germany  
Tel. +49 (0) 25 21 - 24 0  
Fax +49 (0) 25 21 - 24 280  
E-mail: [BEUMER@BEUMER.com](mailto:BEUMER@BEUMER.com)

Further information is available at

**[www.beumer.com](http://www.beumer.com)**