



BEUMER
technology in motion

CONVEYING TECHNOLOGY
LOADING TECHNOLOGY
PALLETIZING TECHNOLOGY
PACKAGING TECHNOLOGY
SORTATION AND
DISTRIBUTION SYSTEMS



BEUMER stretch hood® M

BEUMER stretch hood® M compact – fast – efficient

The BEUMER stretch hood® M is an innovative packaging machine for the securing and protecting of stacked loads. The combination of state-of-the-art control technology, modular design and inventive film handling make the BEUMER stretch hood® M an efficient packaging machine capable of offering solutions to a wide range of packaging requirements:

- high throughput resulting from an optimized over-lapping of movements
- short erection time due to modular design and plug-in wiring
- heavy duty drive units reduce mechanical faults and maintenance
- an ultrasonic sensor automatically determines the exact length of film required per unit load
- machine design allows the handling of stacked loads, containers, appliances, and many other products
- machine design allows container transport

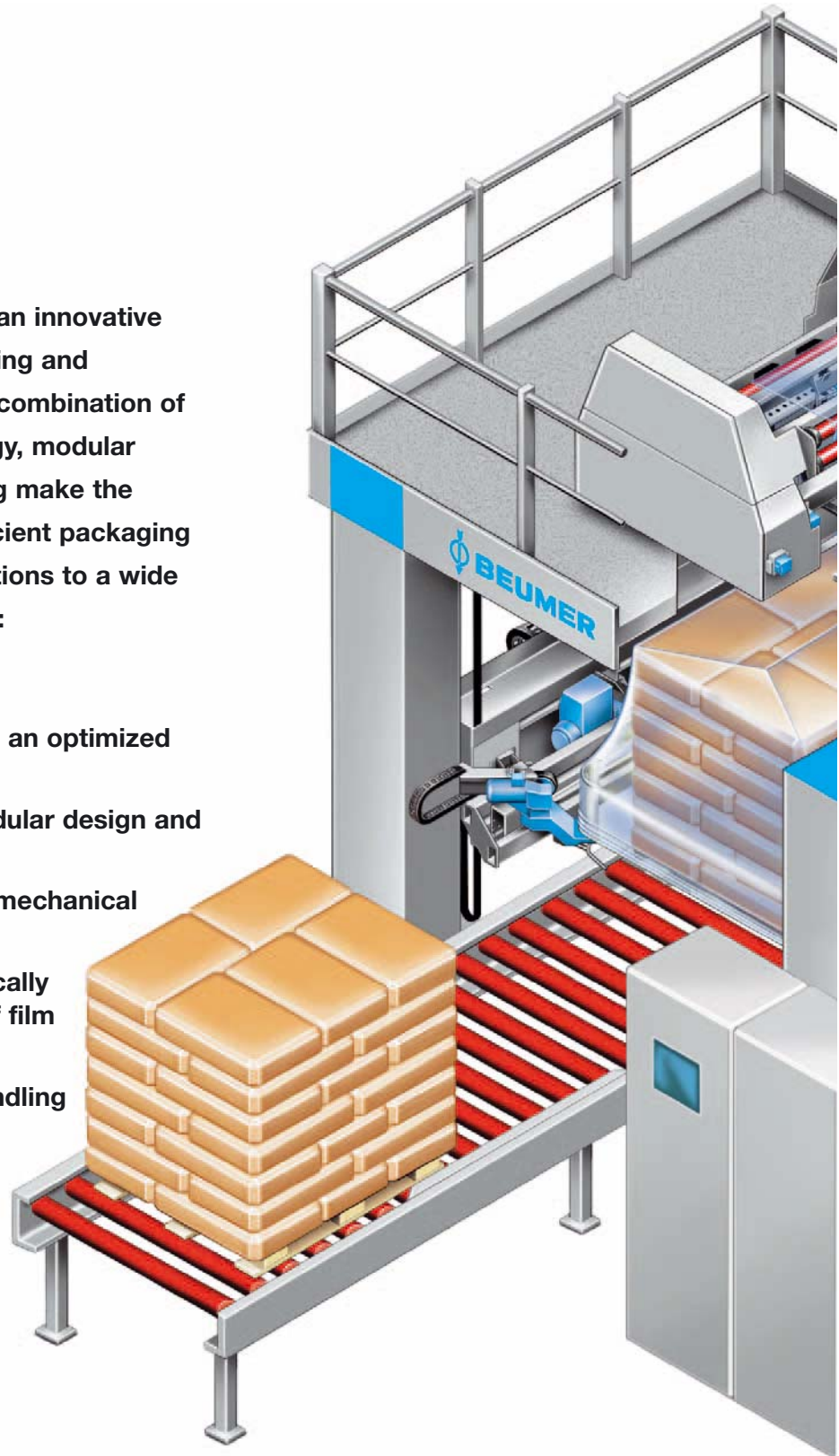

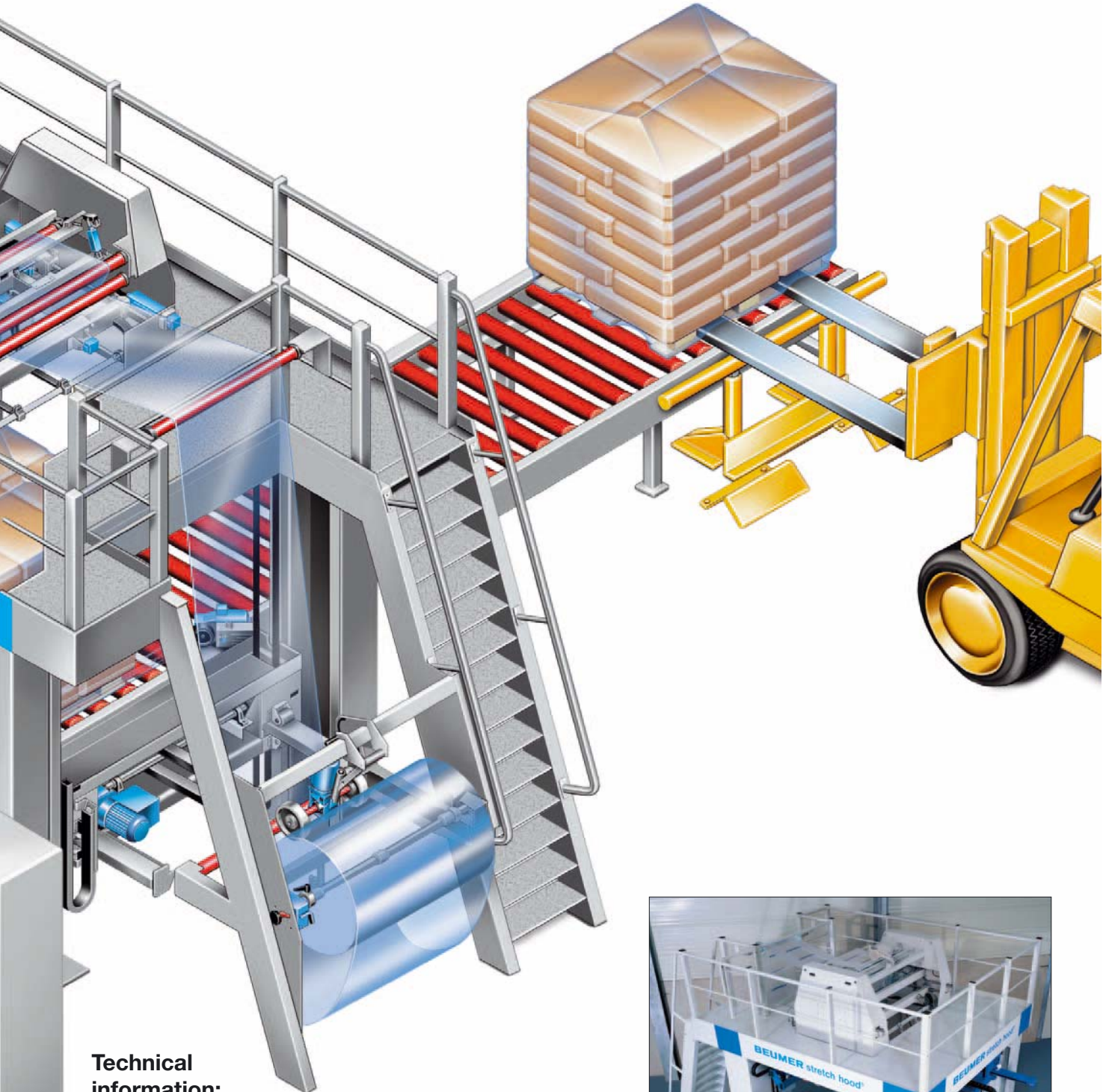

Technical information:

Operating mode	fully automatic film hood stretching
Packaging material	gusseted film tube
Film thickness	40 – 200 µm
Capacity	max. 150 unit loads/h
Package height	up to 2.400 mm
Package dimensions	max. 1.450 x 1.250 mm min. 700 x 700 mm special dimensions on request



Packaging quality: a strong film hood protects the load

- water-tight packaging without an additional flat film sheet
- minimal film consumption
- package stability achieved from both vertical and horizontal film tension
- tight understretch provides excellent adhesion of packaged goods to the pallet
- adjustable film tensions allow pressure sensitive materials to be packaged
- smooth upper surfaces provide display possibilities

Reliability:

No heat energy required

- film and packaged goods will not fuse together
- trouble-free securing of hazardous and heat-sensitive materials

Economy:

High efficiency

- low energy consumption
- high capacity
- film's compacting qualities after use simplifies recycling and disposal

BEUMER stretch hood® M

Advanced technology for perfect film fit

In addition to the single-format machine, multi-format machines are available that will handle various size loads on the same machine by automatically changing to the correct size gusseted film tube. The technical advantages are: Moveable film heads for each film tube size; film guide controls; fully automatic and controlled opening and widening of the gusseted film tube; and automatic determination of the film hood length.

The crimping modules have film length and film end detection units. Package stability is achieved through the biaxial film stretch that combines both the vertical and horizontal film tension forces and the understretch drawn up to the underside of the pallet.

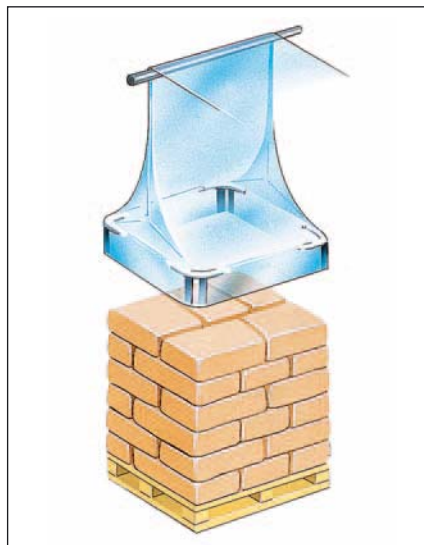

1 Spreading of the film hood and transfer into the crimping and stretching unit

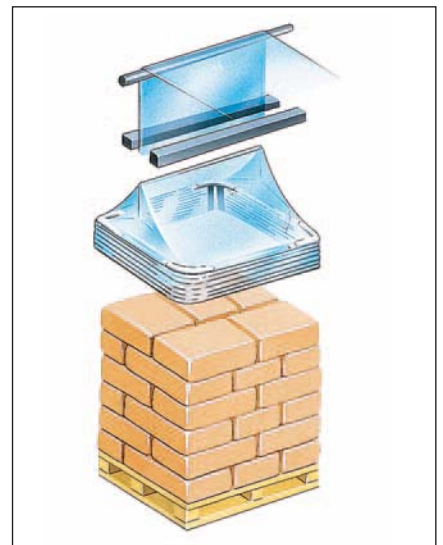

2 Uniform crimping of the hood; sealing and lengthening to a particular size which has been determined by previous sensing of the stack height



Maximization of packaging quality, reliability and economic efficiency



Tested process stages provide reliable operation and extended package durability

Process characteristics:

- the special design of the film tube opening system provides a precise position after each step in the process, even when working with difficult films
- precise spreading of the film to the crimping and stretching unit
- uniform mechanical crimping of the film hood
- tear resistant sealing of the gusseted film tube
- adjustable stretching with specially designed stretch angles that permit a biaxial stretch, thereby increasing the stability of the unit load
- safe understretch system
- heavy duty construction with tested, reliable machine components
- programmable position of the stretch angles

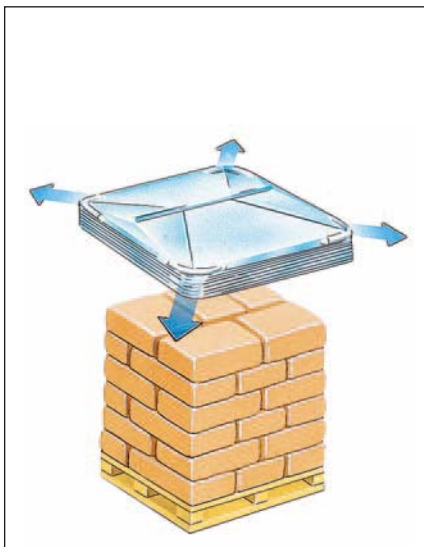

3 Stretching of the hood; the degree of stretch is defined by the stack dimensions, film elasticity and film gusset dimensions

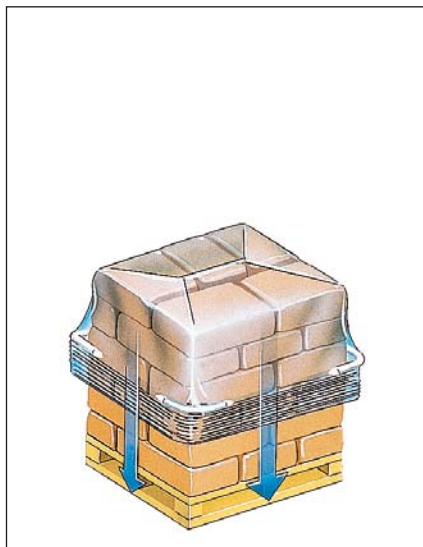

4 Lowering of the stretch angles and simultaneous stretching of the film in a vertical direction: "biaxial stretch"

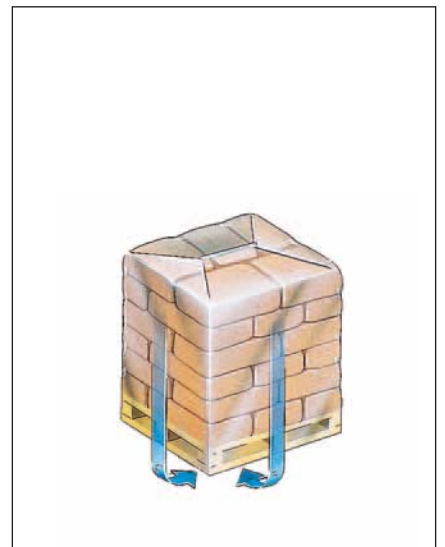

5 Formation of the "understretch"

BEUMER stretch hood® M proven reliable in the chemical industry and the building materials industry

There is a great interest in the use of PE stretch film hoods for securing chemical products and building materials. This interest has

generated a strong demand for alternative solutions to the traditional thermal shrink film or the stretch wrapping packaging methods.

The BEUMER stretch hood method combines the advantages of both these traditional methods and avoids their disadvantages.





BEUMER
technology in motion

Due to the availability of films with high tensile strength and the tear / pierce resistance a wide range of stacked loads can be handled with ease.

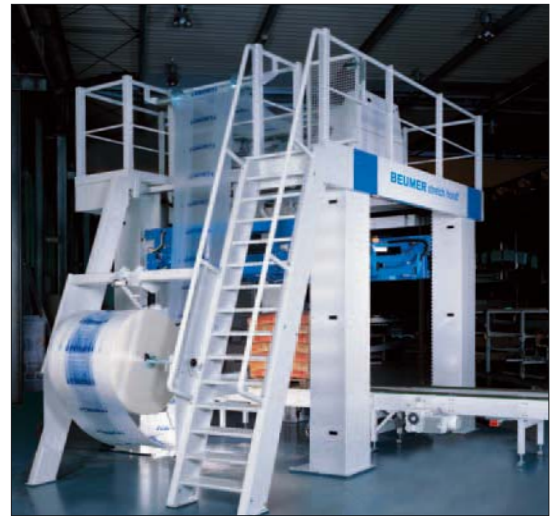

BEUMER stretch hood® M

Industries, including freight forwarders, are demanding the use of protective film coverings for unit loads. The BEUMER stretch hood® M technology meets the strict requirements set forth for packaging quality, economic efficiency and operational reliability.

For more than 20 years BEUMER is experienced in the field „stretch film hood packaging“. Since that time BEUMER has proven its competence successfully in a huge number of projects being realized worldwide. Due to the constant further development of the technical

state in the own company, today BEUMER has taken over the role of being the leader in technology. BEUMER disposes of all main patents allowing the user to benefit from the advantages of the stretch film packaging in an optimal way.





BEUMER
technology in motion

Protection during transport against dust and weather for valuable products

The packaging film utilized for the BEUMER stretch hood® M has a great deal of positive features. The film manufacturer can supply film with the required coefficient of linear expansion and the biaxial stretch to meet all operating conditions. The examples shown

on this page point out the advantages of the perfectly smooth, non-perforated surfaces and the often required ability to show advertising display. The method of securing the film to the pallet, the understretch, guarantees the unit load stability and the

safe transport of products from the manufacturer to the final customer.



and for many other fields of application

There are many other applications for stretch film packaging. A brief selection of the wide range of different products is shown in the adjoining photos. The BEUMER stretch hood® M configuration is variable and can be adapted to the requirements of a wide range of production

demands. The stretch hood package size is usually determined by the standard pallet sizes used by the clients. Different stack heights are automatically determined by the programmable machine controls.





Technical information

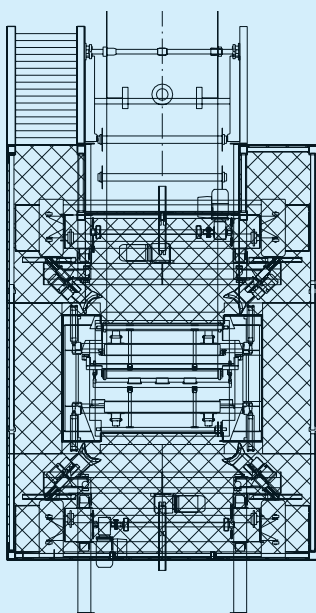
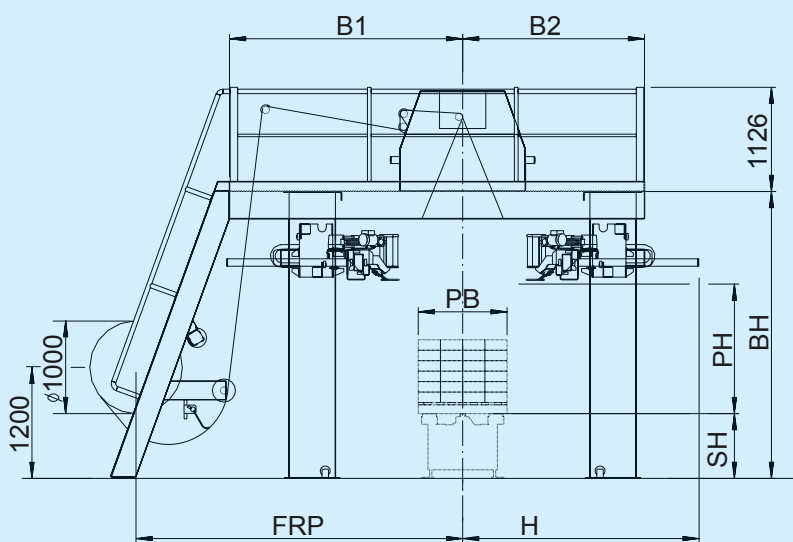
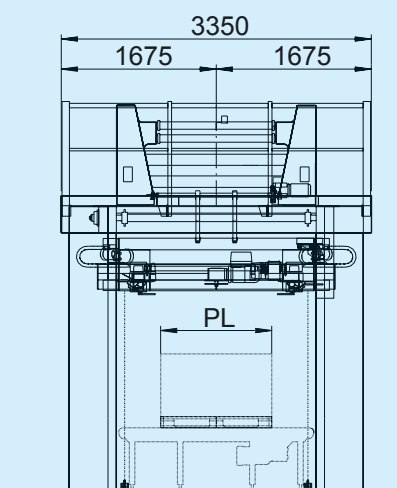

PL package length	PB package width	SH system height	PH package height	BH platform height	B1 platform length 1	B2 platform length 2	FRP position of film reel	H
700-1450	700-1250	700	1400	3100	2070-2520	1740-1965	3080-3530	2105-2555
			1600	3300			3155-3605	
			1800	3500			3230-3680	
			2000	3700			3300-3750	
			2200	3900			3375-3825	
			2400	4100			3445-3895	

*all dimensions approximate



PROGRAM OF SUPPLY

CONVEYING TECHNOLOGY

- Conventional and closed belt conveyor systems
- Overland conveyors also in curved design
- High capacity belt and chain bucket elevators
- Apron conveyor systems with chains or steel cable reinforced belts as traction element
- Bag handling systems for packing plants
- Screw conveyors in various designs

LOADING TECHNOLOGY

- Plants for loading of bulk or bagged material onto trucks, into railroad vehicles and ships
- Semiautomatic railcar unloading machines
- Automatic bag loading systems for trucks and containers

PALLETIZING TECHNOLOGY

- Palletizing robots
- Automatic high capacity palletizers
- Automatic depalletizers
- Pallet conveying systems

PACKAGING TECHNOLOGY

- Stretch wrapping
- Shrink wrapping
- Stretch hood wrapping
- Palletless shrink wrapping

SORTATION AND DISTRIBUTION SYSTEMS

- Computer-controlled handling, sorting and distributing systems for piece goods
- Routing controlled conveying of pallets and collected loads



The information contained in this brochure merely serves as a non-binding description of our products and is without guarantee. Binding information, in particular relating to capacity data and suitability for specific applications, can only be provided within the framework of concrete inquiries.

E402 0506

BEUMER Maschinenfabrik GmbH & Co. KG

Postfach 12 54
D - 59267 Beckum/Germany
Tel.: +49 - (0) 25 21 - 24 0
Fax: +49 - (0) 25 21 - 24 280
E-Mail: BEUMER@BEUMER.com
Internet: www.BEUMER.com

BEUMER Corporation
Branchburg, NJ 08876/USA
Tel.: +1 (732) 560-8222
Fax: +1 (732) 563-0905

BEUMER S.a.r.l.
St. Ouen L'Aumone/France
Tel.: +33 (0) 1-3464-2520
Fax: +33 (0) 1-3037-6883

Asia Representative Office
of BEUMER • Bangkok/Thailand
Ph.: +66 (0) 2731-7190
Fax: +66 (0) 2731-7194

Australian Representative Office
of BEUMER • North Ryde / Australia
Ph.: +61 (0) 2-9889-5561
Fax: +61 (0) 2-9889-5562

BEUMER Ltda.
Campinas - SP/Brazil
Tel.: +55 (0) 19-3243-1700
Fax: +55 (0) 19-3242-1411

BEUMER Technology India
Private Limited • Mumbai/India
Tel.: +91 (0) 22-2577-2874
Fax: +91 (0) 22-2577-2876

伯曼机械制造(上海)有限公司
中国上海
电话: +86 (0) 21-6921-3788
传真: +86 (0) 21-6921-3628