



BEUMER
technology in motion

CONVEYING TECHNOLOGY
LOADING TECHNOLOGY
PALLETIZING TECHNOLOGY
PACKAGING TECHNOLOGY
SORTATION AND
DISTRIBUTION SYSTEMS



**System technology for the use of
scrap tires and other alternative fuels
for kiln firing in the cement industry**

Energetic utilization of scrap tires and other waste solid fuels

The required energy input causes about 40% of the production costs for the manufacture of cement. Therefore apart from standard combustibles like coal, fuel oil and

gas the so called alternative fuels are of considerable interest, besides a useful waste disposal their utilization offers important economical advantages.





Next to waste oil, scrap tires, shredded tires, well as shredded wood, synthetic materials, and oil saturated mineral substances are suitable waste or secondary fuels.

Possible alternative fuels are available in large quantities and at a favorable price. They can be disposed in the high temperature process of the rotary kiln systems of cement plants without any risk. There is neither a danger of inadmissible environmental pollution like toxic emissions nor a reduction of the quality of the cement.

During the high temperature process all contaminants are completely destroyed at a material temperature of approx. 1,450° C and gas temperatures of 2,000° C.

Apart from their energetic utilization alternative fuels also allow a considerable material contribution to the quality of the cement. Their ashes add important mineral components to the cement clinker.

Rubber is the main source of energy when burning scrap tires and the steel belt supplies ferric oxide which otherwise would have to be added in other forms.



About 2/3 of the energy are used thermally with a firing efficiency of more than 90 % and 1/3 of the material is totally used up.

The production of cement is a process of material transformation consisting of all methods necessary to avoid the emission of harmful substances. The aspects of environmental friendly technology

are particularly taken into consideration with regard to the stipulated maximum permissible values of combustion gas.

Since the beginning of the eighties a large number of installations has been using alternative fuels. Long term experience gained since that time has proven the tremendous advantages of this technology.





Economical utilization and sensible disposal of scrap tires



The storage area

Because of the increase in motorization, more and more tires are dumped at landfill. Due to the large material quantities needed their outer nature and the unit weight which can amount to a maximum of 80 kg, the energetic utilization of scrap tires as an alternative fuel requires an automatic handling system. The manual handling of this task has to be excluded, the dumping of the tires in the storage area as well as all further handling processes are preferably done by means of bucket-wheel reclaimers

and gantry cranes with polygon grippers. The size of the storage area should correspond to the kiln capacity and fulfill a buffer function between the irregular delivery of scrap tires and their continuous consumption. As for the construction and operation of these storage areas, federal and local laws will apply. The storage area has to be designed in such a way that rain-water can drain and that absolutely no toxic substances will contaminate the soil.

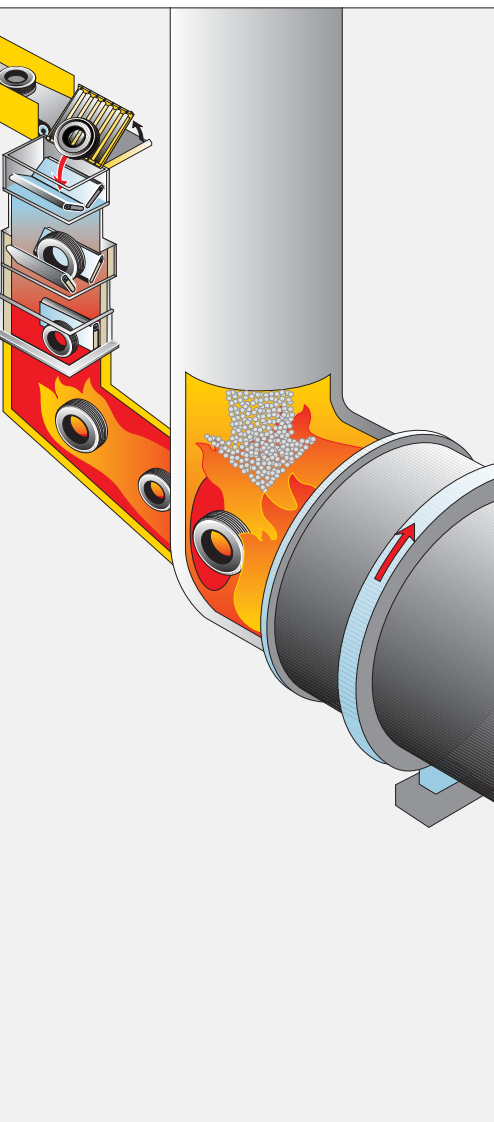

Scrap tires from delivery to the burning process

The machine technology

The handling of scrap tires requires a special know how as well as a particular technology.

The difficulty is to grant a secure, controlled and automatic operation independent of the condition of the tires as well as the weather conditions. This is highly important due to the fact that the kiln process and consequently the quality of the cement clinker are influenced by the supply of fuel.

With regard to their construction and function the single machine components must be suitable for the scrap tires of random size and quality. The special criteria are: size, form, weight and degree of dirt content, some tires still have their steel rim and almost all of them have a considerable quantity of water in their hollow body. Therefore a corresponding preparation is necessary and unsuitable tires have to be rejected by means of a control device.

Construction groups of the feeding system



Storage bin with filling pit and discharge bin



Automatically working gantry crane with polygon gripper for the storage and discharge of scrap tires



Supply box as an alternative to the storage area with filling pit

Illustration showing the variable design of a fully automatic storage

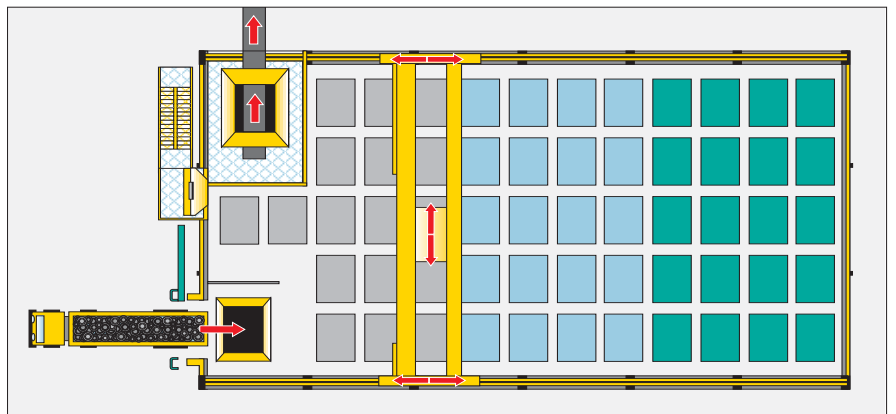



Steep incline conveyor to connect the preparation area installed at ground level with the kiln inlet in the preheater arranged at higher level. The design, the speed and the constructional size of the steep incline conveyor always correspond to the particular requirements of each project.



Kiln inlet valve in multiple step design with shut-off devices to avoid heat loss and leakage of air. The opening impulses are activated by the impact of the falling tire.



Additionally the kiln valve is equipped with manually operated flaps for the emergency operation as well as for necessary inspections. The metallic materials used are protected by highly heat resistant materials.

Electrical control

The electrical control is equipped with a storage programmable electronic system. All storage and supply functions are controlled by means of photocells insensitive to dirt. The drives are equipped with inspection switches so that in case

of disturbances a single segment can be manually operated. The control cabinet is weatherproof and arranged in a heatable room. Any faults are indicated at the control station of the kiln to assure fast troubleshooting.

Process of feeding the fuel into the kiln

The design of the kiln inlet valve and its functional shape essentially depend on the type of fuel to be fed. Whole tires require a specifically different supply than for example shredded materials, the throughput capacity and the related calorific value determine the opening intervals which are realized by the process control of the kiln.

The valve system consists of three steps connected in series which can be designed as flat slide valves or swivel valves. The upper and central step open and close in forced order to protect the kiln operation against heat loss and leakage of air. The lower step has the function of a shut off device in case of faults or inspections.

The system is operated by means of external compressed air cylinders with counterweight balance and position control. The lower step can be adjusted manually for emergency operation. The metallic materials used are protected by highly heat resistant materials.

Slide valve for whole tires

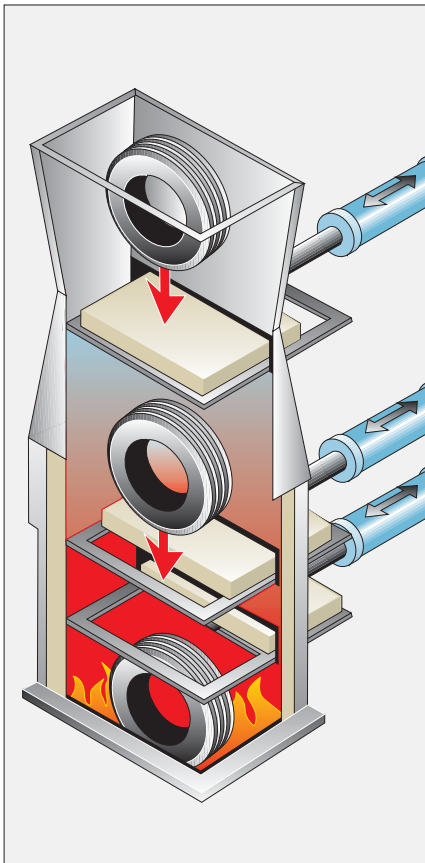

Swivel valve for whole tires

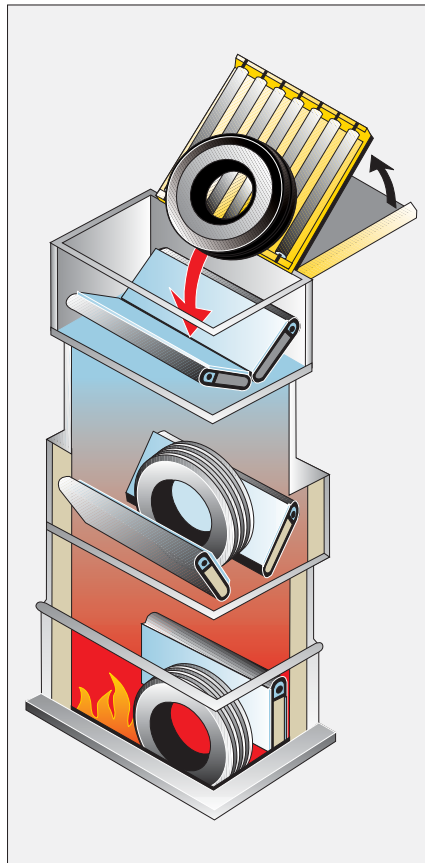

Swivel valve for shredded combustibles

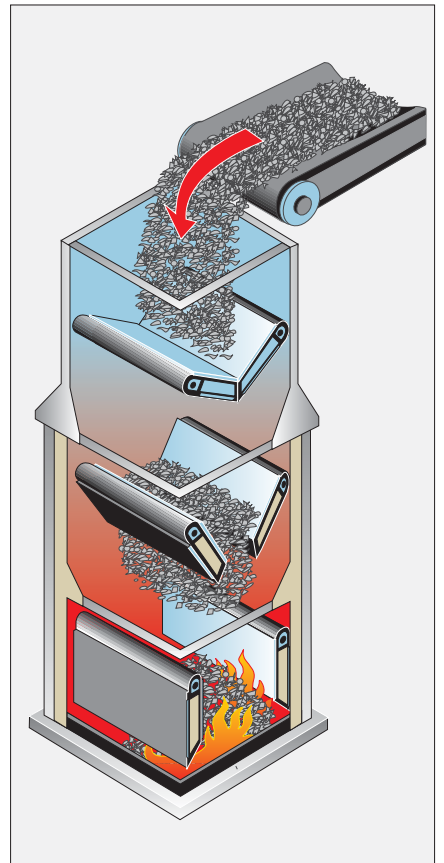



- ① Total construction of a triple flap valve.
- ② Combination of a swivel valve with a flat slide valve for emergency operation
- ③ Swivel valve, interior view of the upper inlet step
- ④ Swivel valve, central inlet step with direct passage into the kiln.



BEUMER system technology as installation concept for the thermal utilization of alternative solid fuels in the high-temperature process of rotary cement kilns

Example of a project for the burning of shredded material and scrap tires

Apart from scrap tires there is also a strong requirement for the thermal utilization of rubber shreds as well as other complementary combustibles which are mostly shredded such a synthetic materials, wood or oil saturated substances, mineral materials from the food industry and waste oil regeneration.

Therefore, modern concepts aim at a flexible use with a quick adjustment to the different types of fuels. Thus the user has the advantage of adjusting his energy balance with regard to the costs always to the present market situation.

The BEUMER system technology is designed to meet these particular demands of construction and functionality. Due to the modular design of all construction groups and system components, each project can be individually planned with regard to capacity requirements.

For more than two decades BEUMER has gained experience in the development of systems for the burning of secondary fuels and during this period a large number of projects has been realized. Knowledge, supplies, and engineering services are part of the support when dealing with BEUMER.

Experience as well as the continuous development in the field of the energetic utilization of solid waste fuels have led to the demand for an exploitation of all products offered in this market.

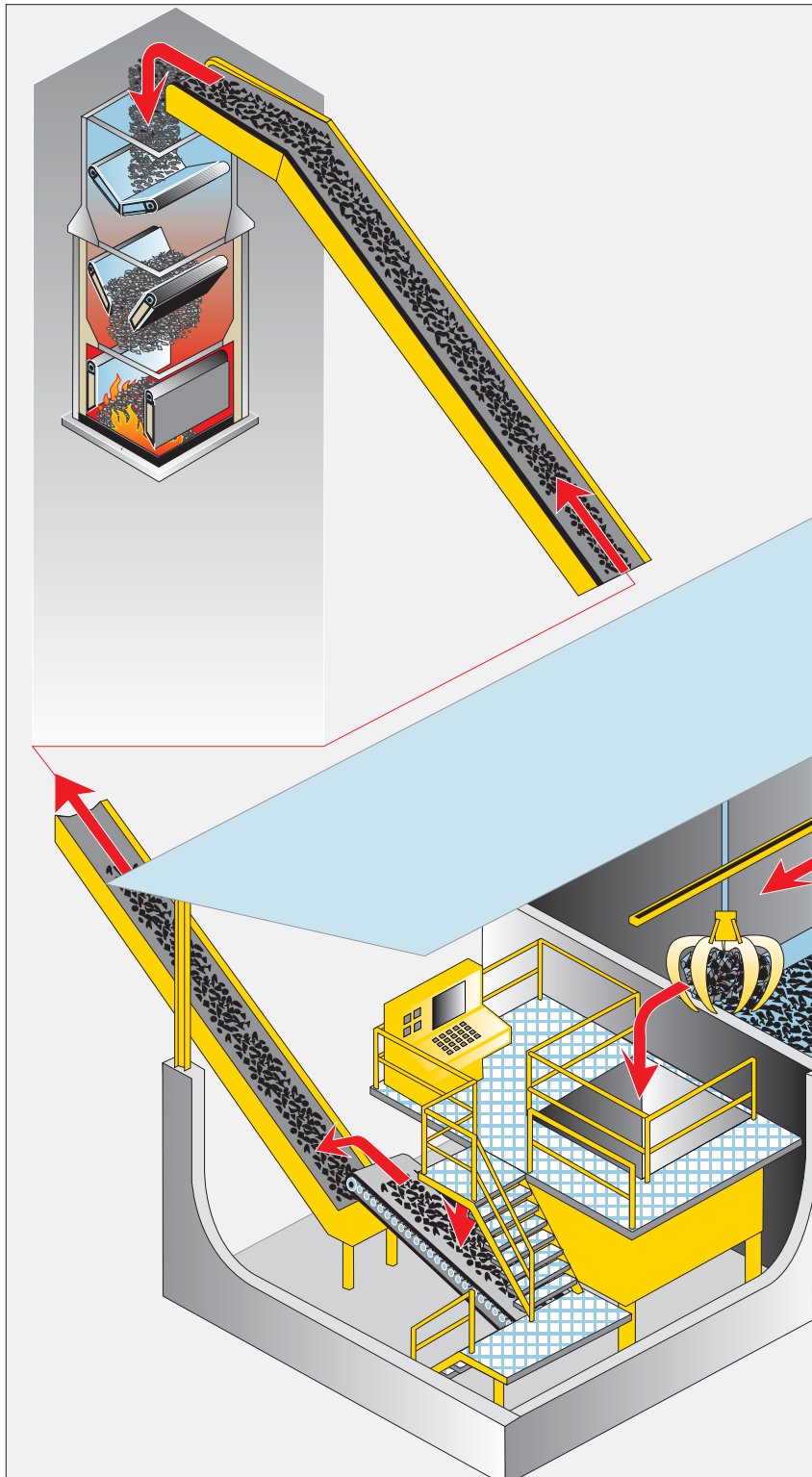

Exemplary illustration of a virtual installation with all essential operating and machine elements.



BEUMER
technology in motion

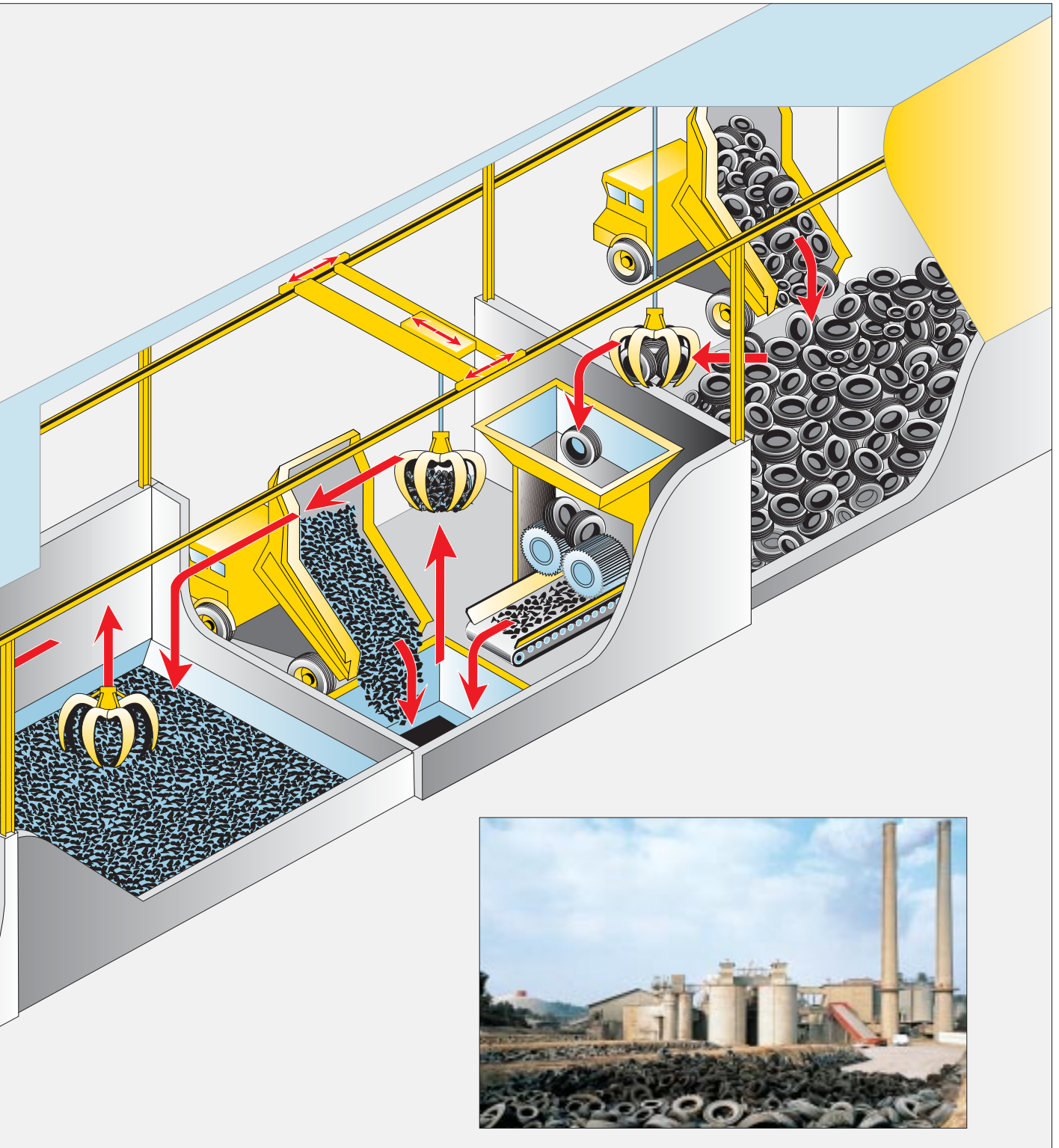



BEUMER
technology in motion

PROGRAM OF SUPPLY

CONVEYING TECHNOLOGY

- Conventional and closed belt conveyor systems
- Overland conveyors also in curved design
- High capacity belt and chain bucket elevators
- Apron conveyor systems with chains or steel cable reinforced belts as traction element
- Bag handling systems for packing plants
- Screw conveyors in various designs

LOADING TECHNOLOGY

- Plants for loading of bulk or bagged material onto trucks, into railroad vehicles and ships
- Semiautomatic railcar unloading machines
- Automatic bag loading systems for trucks and containers

PALLETIZING TECHNOLOGY

- Palletizing robots
- Automatic high capacity palletizers
- Automatic depalletizers
- Pallet conveying systems

PACKAGING TECHNOLOGY

- Stretch wrapping
- Shrink wrapping
- Stretch hood wrapping
- Palletless shrink wrapping

SORTATION AND DISTRIBUTION SYSTEMS

- Computer-controlled handling, sorting and distributing systems for piece goods
- Routing controlled conveying of pallets and collected loads



The information contained in this brochure merely serves as a non-binding description of our products and is without guarantee. Binding information, in particular relating to capacity data and suitability for specific applications, can only be provided within the framework of concrete inquiries.

E105 0107

BEUMER Maschinenfabrik GmbH & Co. KG

Postfach 12 54
D - 59267 Beckum/Germany
Tel.: +49 - (0) 25 21 - 24 0
Fax: +49 - (0) 25 21 - 24 280
E-Mail: BEUMER@BEUMER.com
Internet: www.BEUMER.com

BEUMER Corporation
Branchburg, NJ 08876/ USA
Tel.: +1 (732) 560-8222
Fax: +1 (732) 563-0905

BEUMER Ltda.
Campinas - SP/Brazil
Tel.: +55 (0) 19-3243-1700
Fax: +55 (0) 19-3242-1411

BEUMER S.a.r.l.
St. Ouen L'Aumone/France
Tel.: +33 (0) 1-3464-2520
Fax: +33 (0) 1-3037-6883

BEUMER Technology India
Private Limited • Mumbai/India
Tel.: +91 (0) 22-2577-2874
Fax: +91 (0) 22-2577-2876

Asia Representative Office
of BEUMER • Bangkok/Thailand
Ph.: +66 (0) 2731-7190
Fax: +66 (0) 2731-7194

伯曼机械制造(上海)有限公司
中国上海
电话: +86 (0) 21-6921-3788
传真: +86 (0) 21-6921-3628

Australian Representative Office
of BEUMER • North Ryde / Australia
Ph.: +61 (0) 2-9889-5561
Fax: +61 (0) 2-9889-5562

OOO BEUMER
Moscow/Russia
Tel.: +7 495-945 2818
Fax: +7 495-945 0641